

**RX<sup>3</sup> M.C.B. 6000 A up to 40 A**  
**(1 module per pole)**

Cat. N° (s): 4 199 25 to 4 199 30 - 4 199 34 to 4 199 39



**CONTENTS**

PAGES

1. Description, use.....	1
2. Range.....	1
3. Overall dimensions.....	1
4. Preparation - Connection .....	1
5. General characteristics .....	2
6. Compliance and approvals .....	5
7. Equipments and accessories .....	5

**1. DESCRIPTION - USE:**

. Thermal-magnetic circuit breaker (MCB) with positive contact indication for control, protection against short-circuits and overloads, and isolation of electrical circuits.

**Symbol :**

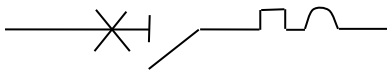

**Technology:**

- . Limiting device
- . 1 Module (17,8) per pole

**2. RANGE**

**Rated currents:**

- . 10 / 16 / 20 / 25 / 32 / 40 A

**Polarity:**

- . 1P+N, 2P

**Magnetic tripping curves :**

- . C curve (between 5 and 10 In)

**Breaking capacity and Rated voltage (50/60 Hz):**

- . 6000 A in accordance with standard EN/IEC 60898-1
- . 1P+N 230 V ~
- . 2P 400 V ~

**3 OVERALL DIMIENSIONS**

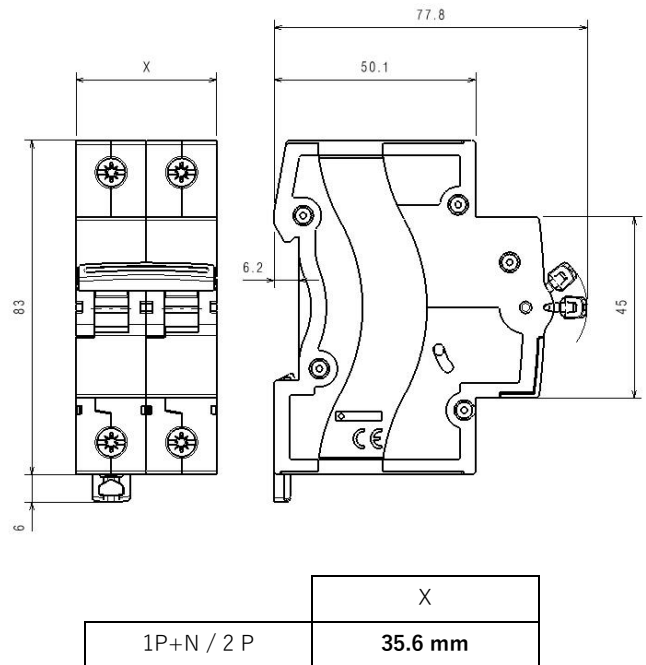

**4. PREPARATION - CONNECTION**

**Fixing:**

- . On symmetrical rail EN/IEC 60715 or DIN 35 rail.

**Operating positions:**

- . Vertical      Horizontal      Upside down      On the side

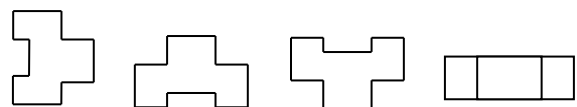

**Power supply:**

- . From the top or from the bottom.

# RX<sup>3</sup> M.C.B. 6000 A up to 40 A (1 module per pole)

Cat. N° (s): 4 199 25 to 4 199 30 - 4 199 34 to 4 199 39

## 4. PREPARATION - CONNECTION *(continued)*

### Connection:

- . Inputs and outputs via screw terminals
- . Cage terminals, with release and captive screws
- . The location of the terminals allows supplying by traditional HX<sup>3</sup> pin busbar.

### Terminal depth :

- . 14 mm

### Stripping length recommended:

- . 11 mm

### Screw head:

- . Mixed, slotted and Pozidriv 2.

### Tightening torque:

- . Recommended: 2.5 Nm.
- . Mini: 2 Nm. Maxi: 3 Nm.

### Tools required:

- . For the terminals: Pozidriv n° 2 or flat screwdriver 5.5 mm (6 mm maximum).
- . For fixing: flat screwdriver 5.5 mm (6 mm maximum).

### Connectable section:

	Copper cables	
	Without ferrule	With ferrule
Rigid cable	1 x 1.5 mm <sup>2</sup> to 35 mm <sup>2</sup> 2 x 1.5 mm <sup>2</sup> to 16 mm <sup>2</sup>	-
Flexible cable	1 x 1.5 mm <sup>2</sup> to 25 mm <sup>2</sup> 2 x 1.5 mm <sup>2</sup> to 10 mm <sup>2</sup>	1 x 1.5 mm <sup>2</sup> to 25 mm <sup>2</sup>

### Manual actuation of the MCB:

- . Ergonomic 2-position handle: ON and OFF

### Contact status display:

- . By front face marking:
  - "O-OFF" = contacts open
  - "I-ON" = contacts closed

### Sealing:

- . Possible in "Open" position (OFF) or "Close" position (ON).

### Locking:

- . By 5 mm padlock (cat. N° 4 063 13) or 6 mm padlock (cat. N° 0 227 97) with padlock support (cat. N° 4 063 03).

## 5. GENERAL CHARACTERISTICS

### Marking on the front side:

- . By permanent ink pad printing:
  - Trade name: RX<sup>3</sup>
  - Tripping curve. [W]
  - Rated current (in A) [XX]
  - Contact status.
  - Icn in A rated breaking capacity in accordance with EN/IEC 60898-1 (in a box) [####]
  - Limiting class "3" (in a square)
  - Mark: Legrand.
  - Straight redline.
  - House logo.
  - Line + dot logo.
  - Reference. [YYYY YY]

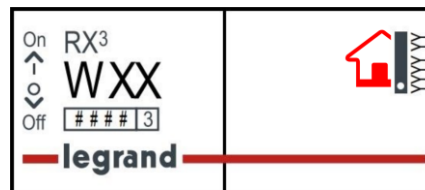

### Top face marking:

- . By permanent pad printing
  - Rated voltage, Electric diagram, (potential Certification logo).



### Side face marking:

- Production information and COPY-TRACER (The Copytracer number ensures that a product is traced and guarantees its production quality).  
Info: <http://www.legrand-copytracer.com/>

# RX<sup>3</sup> M.C.B. 6000 A up to 40 A (1 module per pole)

Cat. N° (s): 4 199 25 to 4 199 30 - 4 199 34 to 4 199 39

## 5. GENERAL CHARACTERISTICS *(continued)*

### Short-circuit breaking capacity:

. Alternate current 50/60Hz, single-phase or three-phase network, in accordance with standard: EN/IEC 60898-1

Un		1P+N	2P
110 V~	I <sub>cn</sub>	<b>10000 A</b>	<b>12500 A</b>
230V~		<b>6000 A</b>	<b>10000 A</b>
400V~		-	<b>6000 A</b>

Un	I <sub>cs</sub>	75% of I <sub>cn</sub>	75% of I <sub>cn</sub>
110 V~			
230V~			
400V~			

. Alternate current 50/60Hz, single-phase or three-phase network, in accordance with standard: EN/IEC 60947-2

Un		1P+N	2P
110 V~	I <sub>cu</sub>	<b>10 kA</b>	<b>12,5 kA</b>
230V~		<b>6 kA</b>	<b>10 kA</b>
400V~		-	<b>6 kA</b>

Un	I <sub>cs</sub>	75% of I <sub>cu</sub>	75% of I <sub>cu</sub>
110 V~			
230V~			
400V~			

### Short-circuit breaking capacity of only one pole:

- . I<sub>cn1</sub> = 6 kA at 230 V, where I<sub>cn1</sub> is the breaking capacity of one pole for multi-pole MCB's in case of short-circuit to earth.
- . Breaking capacity of one single pole under 400 V compound voltage (IT network) = 1.5kA.
- . Breaking capacity of one single pole under 230 V compound voltage (IT network) = 6 kA.

### Minimum operating voltage:

. 12 V a.c. / d.c. per pole.

### Pulse rated voltage:

. U<sub>imp</sub> = 4 kV

### Insulation rated voltage:

. U<sub>i</sub> = 500 V

### Pollution degree :

. 2 in accordance with standard EN/IEC 60898-1.

### Electric strength:

. 2000 V

### Load to close and to open by the handle:

- . 0.1 Nm per pole to close.
- . 0.075 Nm per pole to open.

### Isolating distance (distance between contacts):

. more than 5 mm with the handle in open position O

### Mechanical endurance:

- . 20000 operations without load.
- . 10000 operations with load (under I<sub>n</sub>\*cos φ = 0.9).

### Enclosure material:

- . Compliance with EN/IEC 60898-1
- . Glow-wire test at 960° C in according IEC 60695-2-12
- . Halogens-free

### Average weight per pole:

. 0.130 kg.

### Volume when packed:

	Volume (dm <sup>3</sup> )
1P+N / 2P (packed per 6)	<b>2.0</b>

### Ambient operating temperature:

. Min. = -25° C. Max. = +70° C

### Ambient storage temperature:

. Min. = -40° C. Max. = +70° C

### Degree or class of protection:

- . Protection index the screw head against solid and liquid bodies: IP 20, (in accordance with standards IEC/EN 60529).
- . Protection index of the box against solid and liquid bodies: IP 40 (in accordance with standards IEC/EN 60529).
- . Protection index against mechanical shocks: IK 02 (in accordance with standards EN 50102 and NF C 20-015).

### Dissipated power in case of fire:

. available on request with required Standard

### Power dissipated per pole (W) :

.I <sub>n</sub>	10 A	16 A	20 A	25 A	32 A	40 A
1P ÷ 4 P	<b>1.8</b>	<b>2.2</b>	<b>2.4</b>	<b>3.0</b>	<b>3.2</b>	<b>4</b>

. Impedance per pole (Ω) =  $\frac{P \text{ dissipated}}{I_n^2}$

## 5. GENERAL CHARACTERISTICS *(continued)*:

### Derating of circuit-breakers according to ambient temperature :

. The rated characteristics of a circuit breaker are modified according to the ambient temperature inside the cabinet or the enclosure where the circuit breaker is located.

. Reference temperature: 30 ° C in accordance with EN/IEC 60898-1

In (A)	Ambient Temperature / In									
	- 25° C	- 10° C	0° C	10° C	20° C	30° C	40° C	50° C	60° C	70° C
10	12.5	11.5	11.1	10.7	10.3	10.0	9.7	9.3	9.0	8.7
16	20.0	18.7	18.0	17.3	16.6	16.0	15.4	14.7	14.1	13.5
20	25.0	23.2	22.4	21.6	20.8	20.0	19.2	18.4	17.6	16.8
25	31.5	29.5	28.3	27.2	26.0	25.0	24.0	22.7	21.7	20.7
30	38.3	36.0	34.5	33.0	31.5	30.0	28.8	27.3	26.1	24.9
32	41.0	37.8	36.5	34.9	33.3	32.0	30.7	29.1	27.8	26.5
40	51.0	48.0	46.0	44.0	42.0	40.0	38.0	36.0	34.0	32.0

### Derating of MCB for use with fluorescent lights:

Ferromagnetic and electronic ballasts have a high inrush current for a short time. These currents can cause the tripping of circuit breakers.

At the time of the installation, it should take into account the maximum number of ballasts per circuit breaker that the manufacturers of lamps and ballasts indicate in their catalogues.

### Influence of the altitude:

	≤2000 m	3000 m	4000 m
Dielectric holding	3000 V	2500 V	2000 V
Max operational Voltage	400 V	400 V	400 V
Derating at 30° C	none	none	none

### Derating of MCBs function of the number of devices side by side:

When several MCBs are juxtaposed and operate simultaneously, the thermal evacuation of the poles is limited. This results in an increase in operating temperature of the circuit breakers which can cause unwanted tripping. It is recommended to apply the following coefficients to the rated currents.

Number of circuit breakers side by side	Coefficient
2 - 3	0.9
4 - 5	0.8
6 - 9	0.7
≥ 10	0.6

These values are given by the recommendation of EN/IEC 61439-1.

To avoid using these coefficients, it is necessary to allow a good ventilation and to separate the devices with 0.5 module spacing elements (cat. N° 4 063 07).

## 6. COMPLIANCE AND APPROVALS

### In accordance with standards:

- . EN/IEC 60898-1 with 6000 A breaking capacity
- . EU guidelines : 2014/35/EU + 2014/30/EU
- . Legrand circuit-breakers can be used under the conditions of use as defined by EN/IEC 60947.
- . The performance of circuit breakers can be influenced by particular climates: hot dry, cold dry, hot humid, salt fog atmosphere

### Environment respect – Compliance with EU directives:

- . Compliance with Directive 2011/65/EU of 08/06/11 (RoHS) and subsequent modifications and integrations.

### Precious metal:

- . Silver: 0,04 g per pole  $I_n \leq 32$  A; 0.08 g per pole  $I_n \geq 40$  A
- . No gold

### Packaging:

- . Design and manufacture of packaging in accordance with Directive 94/62/EC

## 7. EQUIPMENT AND ACCESSORIES

### Wiring accessories:

- . Supply busbar

### Possible combinations of MCB's and auxiliaries:

- . No auxiliary is associable to the MCB

### RCD add-on modules:

- . No RCD add-on module